

1#齿轮箱出轴直径 ϕ 18mm配三相电机技术参数

1# GEARBOX WITH SHAFT DIA ϕ 18mm WITH 3-PHASE MOTOR PARAMETERS

■卧式 HORIZONTAL

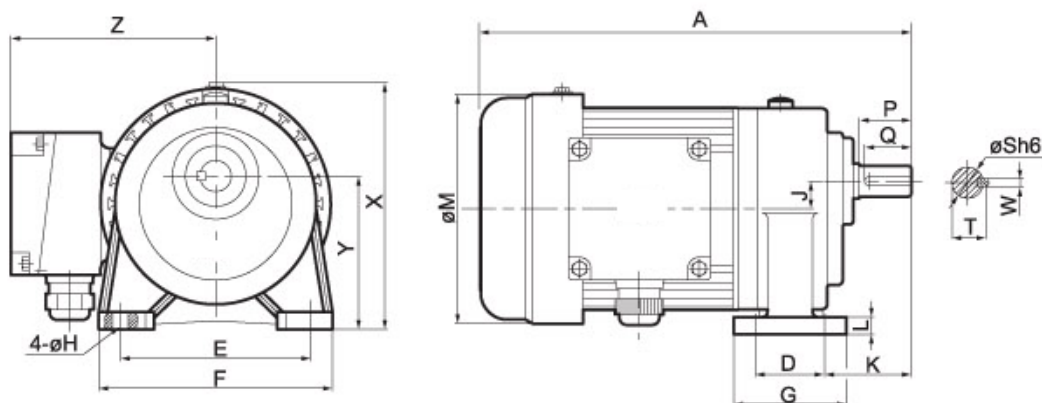

■立式 VERTICAL

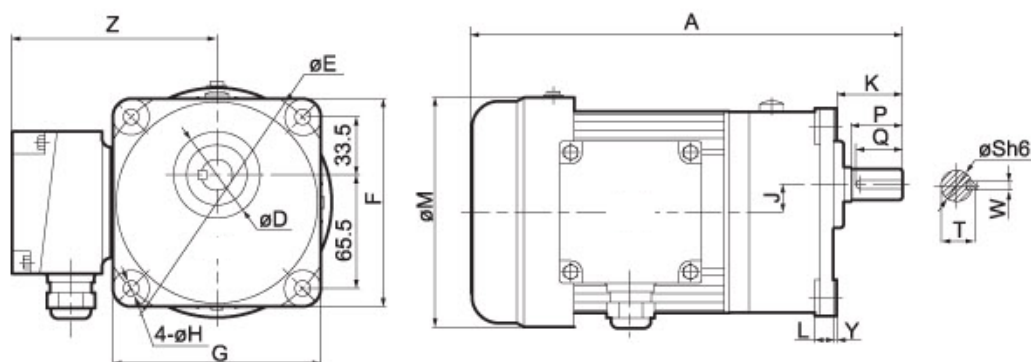

■尺寸表 Size Table

单位Unit: mm

	减速比Ratio	A	D	E	F	G	H	J	K	L	M	X	Y	Z	S	P	Q	W	T	重量Weight
100W 1/8HP	标准型3~50	250	40 (50)	110 (140)	135 (120)	65 (120)	9	16	50 (40)	10.5 (12)	133	138 (/)	88.5 (6)	120	18	30	27	5	20.2	5.7
	缩框型60-200	250	40 (50)	110 (140)	135 (120)	65 (120)	9	16	50 (40)	10.5 (12)	133	138 (/)	88.5 (6)	120	18	30	27	5	20.2	5.7
200W 1/4HP	标准型3~10	280	40 (50)	110 (140)	135 (120)	65 (120)	9	16	50 (40)	10.5 (12)	133	138 (/)	88.5 (6)	120	18	30	27	5	20.2	7.0
	缩框型15-90	280	40 (50)	110 (140)	135 (120)	65 (120)	9	16	50 (40)	10.5 (12)	133	138 (/)	88.5 (6)	120	18	30	27	5	20.2	7.0

※表中()内为立式电机尺寸。

※labulation "()" denote Vertical motor dimension.

■输出轴容许扭矩Output Torque

单位Unit: kg-m

		速 频 率	速 比																			
			3	5	10	15	20	25	30	40	45	50	60	70	80	90	100	120	140	160	180	200
100W 1/8HP	标准型 Standard type	50Hz	0.19	0.31	0.62	0.9	1.2	1.4	1.8	2.2	2.7	2.80	/	/	/	/	/	/	/	/	/	/
		60Hz	0.16	0.26	0.52	0.76	1.00	1.20	1.50	1.90	2.20	2.40	/	/	/	/	/	/	/	/	/	/
	缩框型 Light duty type	50Hz	/	/	/	/	/	/	/	/	/	/	3.40	3.40	3.40	3.40	3.40	3.40	3.40	3.40	3.40	3.40
		60Hz	/	/	/	/	/	/	/	/	/	/	3.40	3.40	3.40	3.40	3.40	3.40	3.40	3.40	3.40	3.40
200W 1/4HP	标准型 Standard type	50Hz	0.37	0.62	1.25	/	/	/	/	/	/	/	/	/	/	/	/	/	/	/	/	/
		60Hz	0.31	0.52	1.04	/	/	/	/	/	/	/	/	/	/	/	/	/	/	/	/	/
	缩框型 Light duty type	50Hz	/	/	/	1.6	2.1	3.2	3.4	3.4	3.4	3.4	3.4	3.4	3.4	3.4	/	/	/	/	/	/
		60Hz	/	/	/	1.3	1.8	2.7	3.2	3.4	3.4	3.4	3.4	3.4	3.4	3.4	/	/	/	/	/	/