

直流电动机 DC MOTORS

15W

60mm

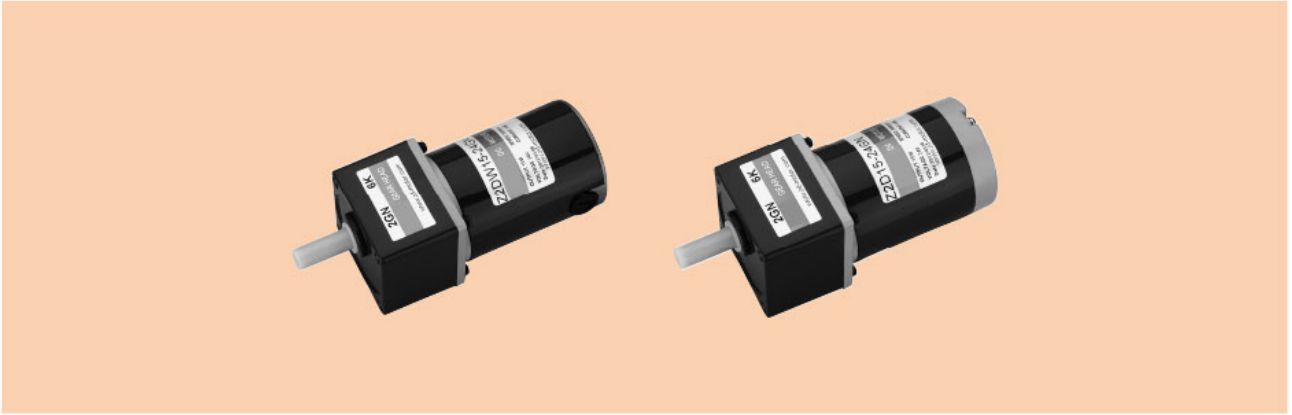

电机性能参数 MOTOR PERFORMANCE PARAMETERS

型号 Model	电压 Voltage V	输出功率 Out put Power W	空载参数No-load Parameters		负载参数Load Parameters			电刷寿命 Brush Life H	电机重量 Motr Weight Kg
			转速Speed r/min	电流Current A	转速Speed r/min	力矩Torque mN.m	电流Current A		
Z2D15-12□	12	15	3200	0.8 Max	2950	48	2.0	2000	0.9
Z2DW15-12□	12	15	3200	0.8 Max	2950	48	2.0	2000	0.9
Z2D15-24□	24	15	3300	0.4 Max	3000	48	1.0	2000	0.9
Z2DW15-24□	24	15	3300	0.4 Max	3000	48	1.0	2000	0.9
Z2D15-90□	90	15	3200	0.2 Max	3000	48	0.4	2000	0.9
Z2DW15-90□	90	15	3200	0.2 Max	3000	48	0.4	2000	0.9

● 电机电压、功率及转速可在配件尺寸等条件下根据客户要求定制。● D后如加W即Z2DW15-12GN表示外置电刷齿轴电机，如无W则为标准内置电刷齿轴电机；外置电刷电机，用户可自行在外部更换电刷；内置电刷电机更换电刷时需将电机拆装后方可更换。

● Motor voltage, power and speed will be customized accrding to his requestment under the allowed circumstance of adoptable dimension. ● WE use W after D in the model to express the external brush motor, such as Z2DW15-12GN. If no W, it means the standard internal brush motor. For external brush motor, you can replce the brush directly. For internal ones, we need to disassembly the motor first.

种类 TYPE

● 电动机 MOTOR

机型 Type	型号 Model	
	齿轮轴型 Pinion Shaft	圆轴型 Round Shaft
导线型 Lead	Z2D15-12GN	Z2D15-12A
Wire	Z2DW15-12GN	Z2DW15-12A
Type	Z2D15-24GN	Z2D15-24A
	Z2DW15-24GN	Z2DW15-24A
	Z2D15-90GN	Z2D15-90A
	Z2DW15-90GN	Z2DW15-90A

● 平行轴减速器(另售) PARALLEL SHAFT GEARHEAD (SOLD SEPARATELY)

减速器种类 Gearhead Type	减速器型号 Gearhead Model	减速比 Gear Ratio
长寿命·低噪音 Long Life·Low Noise	2GN□K	3、3.6、5、6、7.5、9、 12.5、15、18、25、30、 36、50、60、75、90、 100、120、150、180、200
	2GN10XK(中间减速器Mid-gearbox)	

● 减速器型号的□中为减速比的数值

● Enter the gear ratio in the box (□) within the model name

● 电机特性曲线 Characteristic Curve of Motor

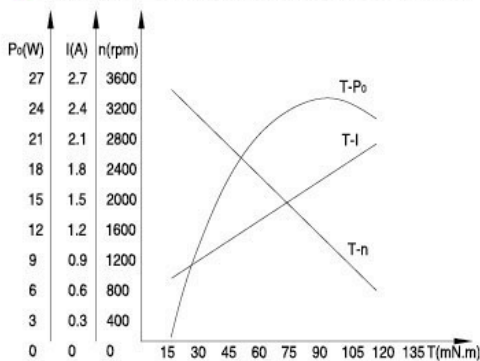

● 电机接线图 Wiring Diagram of Motor

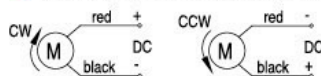

● 标准引出线长度: 300mm±10, 型号: UL1015 规格: AWG20; 电机引出线长度, 型号在配件尺寸等条件允许的情况下可根据客户需求定制

● Stanclard length of lead wire: 300mm±10, model: UL1015 type: AWG20; lead wire length, model will be customised by dient requestmant under allowed circumstance of adoptable dimension

■ 装有减速器时的容许转矩

ALLOWABLE TORQUE WHEN BEING WITH GEARHEAD

- 减速器·中间减速器另售
- 减速器型号的□中为减速比的数值。
- □色表示与电动机同一方向运转，其他则为相反方向。
- 转速是以电动机的额定转速为基准除以减速比而算出来的数值。实际转速将随负载大小变化而比所示数值减少2%~20%左右。
- 希望以大于下表的减速比进行进一步减速时，可在电动机与减速器之间安装减速比为10的中间减速器。这时的容许转矩为3N·m
- Gearhead and mid-gearbox can be sold separately.
- Enter the gear ratio in the box (□) within the model name.
- □ Indicates the same rotating direction of the motor while the others rotate in the opposite direction.
- The speed is calculated by dividing the motor's synchronous speed by the gear ratio. The actual speed is 2%~20% less than the displayed value, depending on the size of the load.
- To reduce the speed beyond the gear ratio in the table, attach a mid-gearbox (gear ratio: 10) between the gearhead and motor. In that case, the permissible torque is 3N·m.

容许力矩单位 Allowance Torque Unit: 上段 Upside (N.m) / 下段 Belowside (kgf.cm)

机型Type	减速比Gear Ratio	3	3.6	5	6	7.5	9	12.5	15	18	25	30	36	50	60	75	90	100	120	150	180	200
		转速Speed r/min	1000	833	600	500	400	333	240	200	166	120	100	83	60	50	40	33	30	25	20	16
Z2D15-24GN	2GN□K	0.11	0.13	0.19	0.23	0.29	0.34	0.48	0.58	0.69	0.87	1.04	1.25	1.74	1.89	2.36	2.83	3.0	3.0	3.0	3.0	3.0
		1.18	1.42	1.97	2.36	2.96	3.55	4.93	5.92	7.10	8.89	10.6	12.8	17.7	19.2	24.1	28.9	30	30	30	30	30

■ 容许悬挂负载·容许轴向负载

PERMISSIBLE OVERHUNG LOAD AND THRUST LOAD

电动机(圆轴型)→P217
减速器→P217页

Motor(Round Shaft)→P217
Gearhead→P217

■ 减速器的容许负载惯性惯量J

PERMISSIBLE LOAD INERTIA J FOR GEARHEAD

→P218页→P218

■ 外形图(单位 mm)

DIMENSIONS(Unit mm)

减速器附有安装用螺丝

Mounting screws are included with gearhead.

电动机型号 Motor Model	减速器型号 Gearhead Model	减速比 Gear Ratio	L1
Z2D15-12GN Z2DW15-12GN Z2D15-24GN Z2DW15-24GN	2GN□K	3~18	32
Z2D15-90GN Z2DW15-90GN		25~200	41

- 减速器型号的□中为减速比的数值
- Enter the gear ratio in the box (□) within the model name

● 圆轴型的转轴部分 Shaft Section of Round Shaft Type

除重量及轴部外，电动机外形与齿轴型相同

Excluding weight and the shaft section Motor shape are the same as those of the pinion shaft

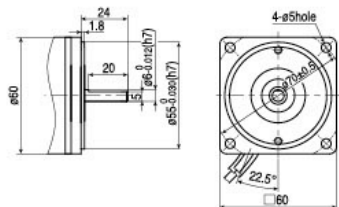

● 导线型 Lead wiring Type

重量 Weight: 电动机 Motor 0.9kg 减速器 Gearhead 0.4kg

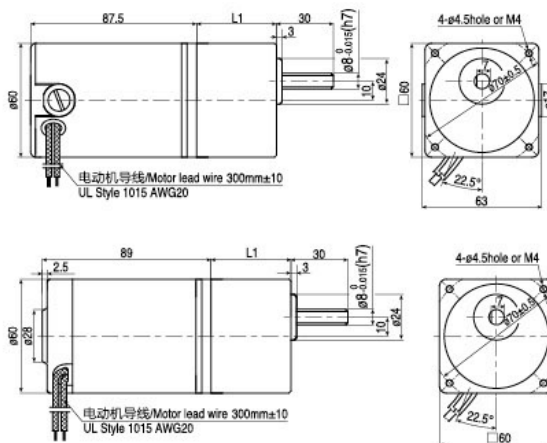

● 中间减速器 Mid-gearbox

可安装在GU齿轮轴型上

Can be connected to GN pinion Shaft type 2GN10XK

重量 Weight: 0.24kg

